



■ SJ

SWIVEL JOINTS

Edition. 21.0

CS Carbon Steel

- Type: swivel joint / at 90°
- Sizes: from DN6 up to DN50
- Ends: BSP- NPT (on request)
- Pressure: up to PN400
- Temp range: from -20°C to +80°C
- Treatment: Galvanized



CODE DESCRIPTION STRUCTURE

SJ	10	G1/2	CS
----	----	------	----

Type and way of valve

SJ swivel joint

10 line
90 90°

Ends

GAS DIN/
ISO 228
BSP

- G 1/4
- G 3/8
- G 1/2
- G 3/4
- G 1
- G 1 1/4
- G 1 1/2
- G 2

Material

- CS carbon steel

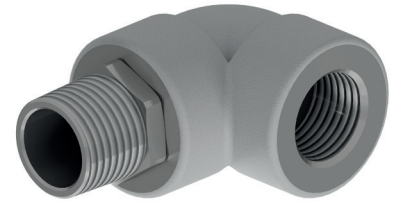

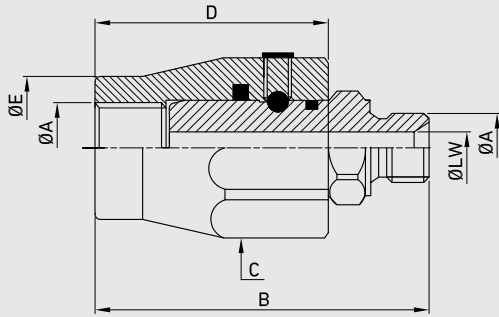

SJ - IN LINE FROM 1/4" TO 1/2"

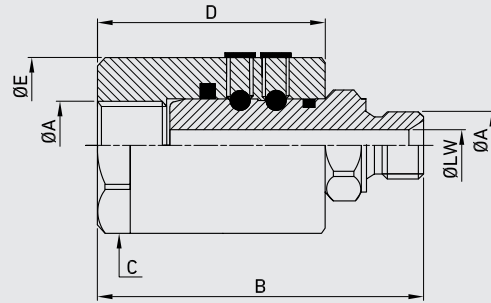

SJ - IN LINE FROM 3/4" TO 2"

SJ - IN LINE FROM 1/4" TO 1/2"

CS
Carbon Steel

TYPE	ØA	C	B	D	ØE	ØLW	MAX ROTATING PRESSURE	MAX STATIC PRESSURE	MAX FLOW L/min	ITEM CODE		
SJ10 IN LINE 1/4 BSP	G 1/4	mm	30	61	42	24	6	MPa	20	40	25	NSJ2G010000
		inch		2,40	1,65	0,94	0,24	Psi	2900	5800		
SJ10 IN LINE 3/8 BSP	G 3/8	mm	34	66	44	25	8,5	MPa	20	40	35	NSJ2G020000
		inch		2,60	1,73	0,98	0,33	Psi	2900	5800		
SJ10 IN LINE 1/2 BSP	G 1/2	mm	36	71	47	32	11,5	MPa	15	30	60	NSJ2G030000
		inch		2,80	1,85	1,26	0,45	Psi	2175	4350		

SJ - IN LINE FROM 3/4" TO 2"

CS
Carbon Steel

TYPE	ØA	C	B	D	ØE	ØLW	MAX ROTATING PRESSURE	MAX STATIC PRESSURE	MAX FLOW L/min	ITEM CODE		
SJ10 IN LINE 3/4 BSP	G 3/4	mm	45	87,5	56,5	49,5	15	MPa	15	30	100	NSJ2G040000
		inch	1,77	3,44	2,22	1,95	0,59	Psi	2175	4350		
SJ10 IN LINE 1" BSP	G 1	mm	50	93,7	61,5	54,5	20	MPa	10	25	180	NSJ2G050000
		inch	1,97	3,69	2,42	2,15	0,79	Psi	1450	3625		
SJ10 IN LINE 1"1/4 BSP	G 1 1/4	mm	55	101	63	60	28	MPa	10	30	270	NSJ2G060000
		inch	2,17	3,98	2,48	2,36	1,10	Psi	1450	4350		
SJ10 IN LINE 1"1/2 BSP	G 1 1/2	mm	65	110	70	69,5	35	MPa	8	30	350	NSJ2G070000
		inch	2,56	4,33	2,76	2,74	1,38	Psi	1160	4350		
SJ10 IN LINE 2" BSP	G 2	mm	75	119	75	84,5	44	MPa	5	30	700	NSJ2G080000
		inch	2,95	4,69	2,95	3,33	1,73	Psi	725	4350		

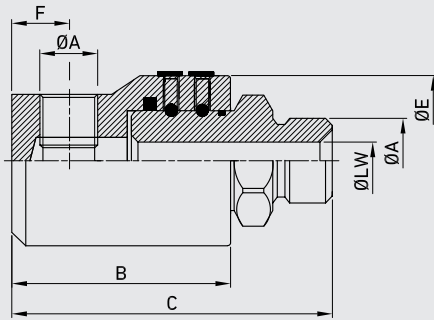
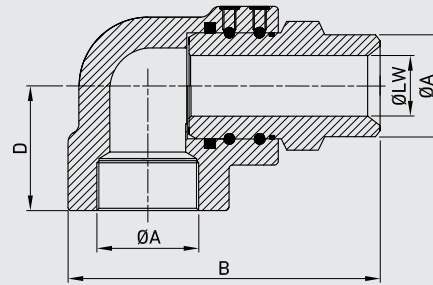
SJ - AT 90° FROM 1/4" TO 1"

SJ - AT 90° FROM 1 1/4" TO 2"
SJ - AT 90° FROM 1/4" TO 1"

											CS Carbon Steel		
TYPE	ØA	B	C	ØLW	ØE	F	MAX ROTATING PRESSURE	MAX STATIC PRESSURE	MAX FLOW L/min	ITEM CODE			
SJ90 AT 90 1/4 BSP	G 1/4	mm	50	70	6	33,5	11	MPa	20	40	25	NSJ1G010000	
		inch	1,97	2,76	0,24	1,32	0,43	Psi	2900	5800			
SJ90 AT 90 3/8 BSP	G 3/8	mm	54	77	8,5	37,5	13	MPa	20	40	35	NSJ1G020000	
		inch	2,13	3,03	0,33	1,48	0,51	Psi	2900	5800			
SJ90 AT 90 1/2 BSP	G 1/2	mm	63	87	11,5	39,5	14	MPa	15	30	60	NSJ1G030000	
		inch	2,48	3,43	0,45	1,56	0,55	Psi	2175	4350			
SJ90 AT 90 3/4 BSP	G 3/4	mm	74	104	15	54,5	19,5	MPa	15	30	100	NSJ1G040000	
		inch	2,91	4,09	0,59	2,15	0,77	Psi	2175	4350			
SJ90 AT 90 1" BSP	G 1	mm	87	119	21	55	60	24	MPa	10	30	180	NSJ1G050000
		inch	3,43	4,69	0,83	2,17	2,36	0,94	Psi	1450	4350		

SJ - AT 90° FROM 1 1/4" TO 2"

											CS Carbon Steel
TYPE	ØA	B	D	ØLW	MAX ROTATING PRESSURE	MAX STATIC PRESSURE	MAX FLOW L/min	ITEM CODE			
SJ90 AT 90 1 1/4 BSP	G1 1/4	mm	119,5	52	28	MPa	10	30	270	NSJ1G060000	
		inch	4,70	2,05	1,10	Psi	1450	4350			
SJ90 AT 90 1 1/2 BSP	G1 1/2	mm	140	62	35	MPa	8	30	350	NSJ1G070000	
		inch	5,51	2,44	1,38	Psi	1160	4350			
SJ90 AT 90 2" BSP	G 2	mm	151	64	44	MPa	5	25	700	NSJ1G080000	
		inch	5,94	2,52	1,73	Psi	725	3625			